

**Modular Cooking Range Line
 thermaline 90 - 4 Zone Full Surface
 Induction Top on Cupboard Base, 1 Side,
 H=800**

ITEM # _____

MODEL # _____

NAME # _____

SIS # _____

AIA # _____

589732 (MCJDFAJ9AA)

 Free-zone Induction on
 cupboard base (34x72x33h
 cm), H2, 4 zones, 1-side
 operated

Short Form Specification

Item No. _____

Unit constructed according to DIN 18860_2 with 20 mm drop nose top and 70 mm recessed plinth. Internal frame for heavy duty sturdiness in stainless steel. 2 mm top in 1.4301 (AISI 304). Flat surface construction, easily cleanable. THERMODUL connection system enables seamless worktop when units are connected and avoids soil penetrating. Free zone multi-coil glass ceramic surface without dead spots can host up to 16 pots&pans. Minimum cookware diameter is 7 mm. UI design to control each coil independently, power (W) and temperature settings are possible. Overheat protection switches off the supply in case of overheating. IPX5 water resistance certification. Configuration: Freestanding, one-side operated, on cupboard base, hygienic class H2.

Main Features

- The free zone induction offers the possibility to use multiple pots and pans, even small sizes (min diameter 7 cm), thanks to the multi-coil system design that makes all the surface active, ideal for à la carte menu.
- The smooth glass-ceramic surface features limited temperature increase and it can be quickly and easily cleaned, thus providing maximum hygiene.
- THERMODUL connection system creates a seamless work top when units are connected to each other thus avoiding soil penetrating vital components and facilitating the removal of units in case of replacement or service.
- 360° round stepless metal knobs, working clock and anticlock wise for quick parameters selection and adjustment.
- Each zone is controlled by a touch-sensitive keypad with 7 touch buttons, 4 displays and a round knob. Each zone consists in 4 coils, which can be individually controlled or bridged in 2, 3 or 4. Power (watts) or temperature (°C) can be selected. A function is also available to set and save 3 different configurations.
- Power setting from 25 to 2000 watt in 30 steps or temperature settings from 30 to 250° C in steps of 1°C.
- Electronic sensor, placed underneath the glass, below the coil center position, to precisely measure the temperature of the pan/pot bottom
- Overheat protection: the temperature sensor switches off the supply in case of overheating.
- Heating system automatically switches off when pots and pans are removed.
- Low heat dissipation to the kitchen.
- Cupboard door handle is ergonomically designed with silicon "soft" grip for easy handling and cleaning.

Construction

- Unit constructed according to DIN 18860_2 with 20 mm drop nose top and 70 mm recessed plinth.
- Flat surface construction with minimal hidden areas to easily clean all surfaces
- Internal frame for heavy duty sturdiness in stainless steel.
- All major components may be easily accessed from the front, including the induction filters.
- 2 mm top in 1.4301 (AISI 304).
- 34x72x33 cm (wxdxh) cupboard base with round corners H2 and door for storage.
- IPX5 water resistance certification.

Sustainability

- This model is compliant with Swiss Energy Efficiency Ordinance (730.02).

Optional Accessories

- Scraper for cook tops PNC 910601
- Connecting rail kit, 900mm PNC 912502

APPROVAL: _____

Front

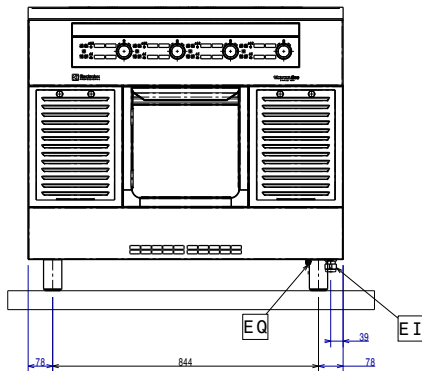

Side

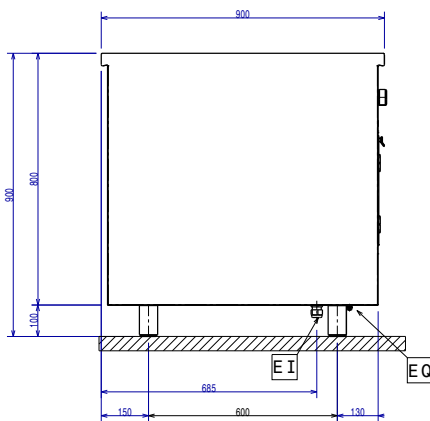

EI = Electrical inlet (power)
 EQ = Equipotential screw

Top

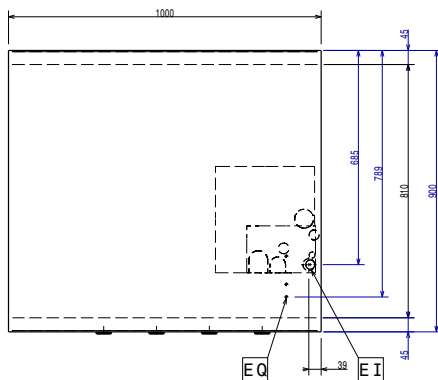

Electric

Supply voltage: 400 V/3N ph/50/60 Hz
 Total Watts: 32 kW

Key Information:

External dimensions, Width: 1000 mm
 External dimensions, Depth: 900 mm
 External dimensions, Height: 800 mm
 Storage Cavity Dimensions (width): 340 mm
 Storage Cavity Dimensions (height): 330 mm
 Storage Cavity Dimensions (depth): 716 mm
 Net weight: 128 kg
 Configuration: On Base;One-Side Operated
 Front Plates Power: 8 - 8 kW
 Back Plates Power: 8 - 8 kW
 Front Plates dimensions: 320x320 320x320
 Back Plates dimensions: 320x320 320x320
 Induction Top Dimensions (width): 1000 mm
 Induction Top Dimensions (depth): 900 mm

Sustainability

Current consumption: 43 Amps